

## AFTERCARE INSTRUCTIONS

In the rare event of missing components or any need for replacements, please contact customer services and use these instructions as reference.

## CUSTOMER SERVICE

t: +44(0)208 686 5100  
e: [technical@saneux.com](mailto:technical@saneux.com)

4 Imperial Way  
Croydon CR0 4RR

[www.saneux.com](http://www.saneux.com)

# FLUSHE

## INSTALLATION INSTRUCTIONS

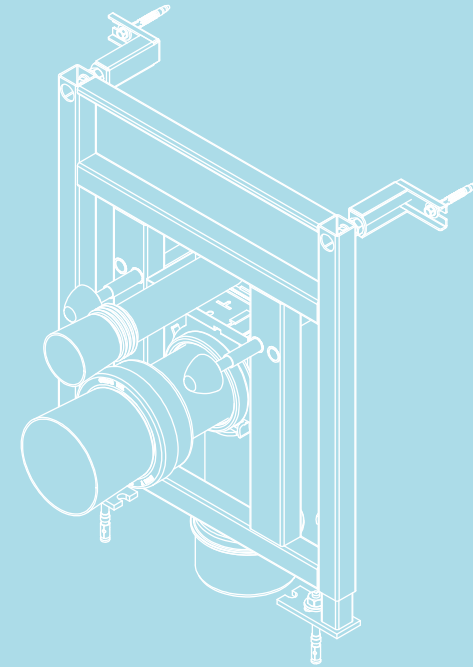

FL5053

saneux

Before commencing installation, ensure all components are present and check the dimensions of the selected pan, cistern and furniture unit against the fitting dimensions of this frame.

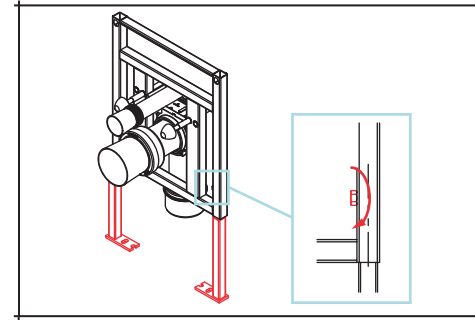
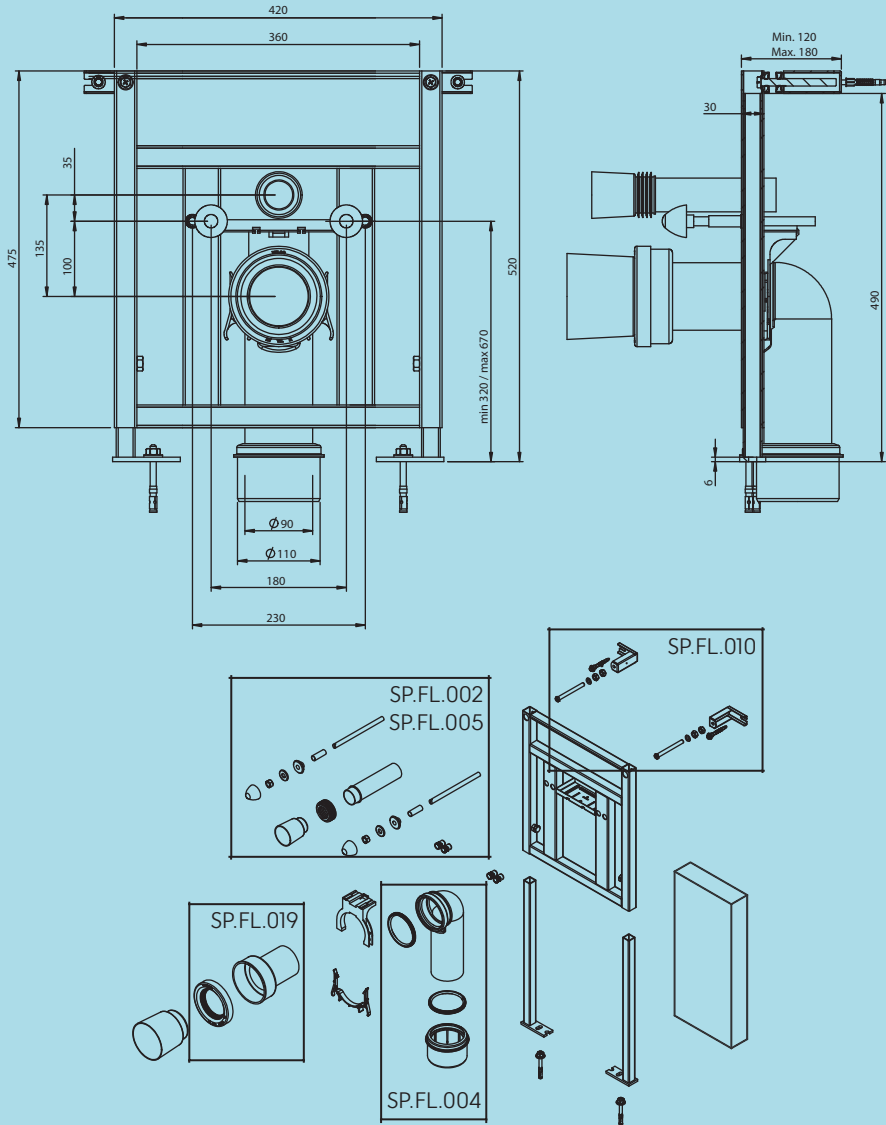

Measure the desired height of the WC and extend the frame accordingly. Ensure the securing nuts are fully tightened.

Mark the location of the fixing holes and drill the wall and floor. Using the fixings provided, secure the frame to the wall and floor.

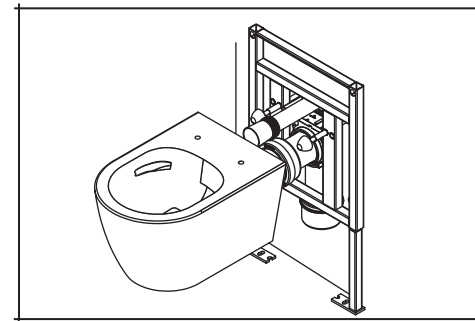
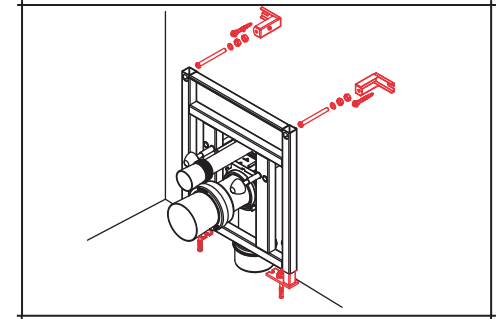

Install the cistern and pan, following their installation instructions. Make sure the pan is tightly fitted and test the system to ensure there are no leaks.